

Science and Technology Create Perfection

# Installation and Operating Manual

## **SR609C SOLAR CONTROLLER**

For Integrated Pressurized Hot Water System



**⚠ Read the instruction carefully please before operation!**

## Contents

1. Safety information .....	2
1.1 Installation and commissioning.....	2
1.2 Liability waiver .....	3
1.3 Description of symbols .....	3
2. Installation.....	4
2.1 Installing the controller.....	4
2.2 Power connection.....	5
2.3 Terminal connection.....	6
3. Installation system diagram .....	7
4. Function setting .....	8
4.1 Display symbol and button array .....	8
4.2 Setting time .....	8
4.3 Manual heating.....	9
4.4 Timing heating .....	10
4.5 Frost protection of collector .....	12
4.6 Anti-Legionella function .....	13
4.7 Pipe insulation function (optional, not available on standard functions list).....	14
4.8 C- F Celsius and Fahrenheit temperature transferring .....	15
4.9Recovery factory setting.....	16
5. Protection function.....	16
5.1. Memory protection.....	16
5.2 Screen protection .....	16
5.3 Trouble protection.....	16
6. Quality Guarantee .....	16
7. Technical data.....	17
8. Delivery scope.....	18
9. Device matchable to this controller.....	18

## 1. Safety information

We have carefully checked the text and pictures of this manual and provided the best of our knowledge and ideas, however inevitable errors maybe exist. Please note that we can not guarantee that this manual is given in the integrity of image and text, they are just some examples, and they apply only to our own system. Incorrect, incomplete and erroneous information and the resulting damage we do not take responsibility.

### 1.1 Installation and commissioning

- When laying cables, please ensure that no damage occurs to any of the constructional fire safety measures presented in the building.
- The controller can not be installed in rooms where easily inflammable gas mixtures are present or may occur.
- The permissible environmental conditions can not be exceeded at the site of installation.
- Before connecting the device, make sure that the energy supply matches the specifications that controller requires.
- All devices connected to the controller must conform to the technical specifications of the controller.
- All operations on an open regulator are only to be conducted cleared from the power supply. All safety regulations for working on the power supply are valid. Connecting and /or all operations that require opening the regulator (e.g. changing the fuse) are only to be conducted by specialists.

## 1.2 Liability waiver

The manufacturer cannot monitor the compliance with these instructions or the circumstances and methods used for installation, operation, utilization and maintenance of this controller. Improper installation can cause damages to material and persons. This is the reason why we do not take over responsibility and liability for losses, damages or cost that might arise due to improper installation, operation or wrong utilization and maintenance or that occurs in some connection with the aforementioned. Moreover we do not take over liability for patent infringements or infringements – occurring in connection with the use of this controller- on third parties rights. The manufacturer preserves the right to put changes to product, technical data or installation and operation instructions without prior notice. As soon as it becomes evident that safe operation is no longer possible (e.g. visible damage). Please immediately take the device out of operation. Note: ensure that the device cannot be accidentally placed into operation.

## 1.3 Description of symbols



Safety instruction:

The safety instructions in the manual are marked with a warning triangle. It indicates measures, which can lead to personal injury and safety risks.

Operation steps: small triangle “▶” is used to indicate operation step.

Notes: Contains important information about operation or function.

## 2. Installation

Controller can only be installed indoors, and is far away from dangerous place and away from the electromagnetic field. Controller should be equipped with an additional plug, which should have minimum 3mm distance between the pole of the plug or effective compliance with the provisions of the installation. For example, switch or fuse, please note wires should be separated, and use the AC.

### 2.1 Installing the controller

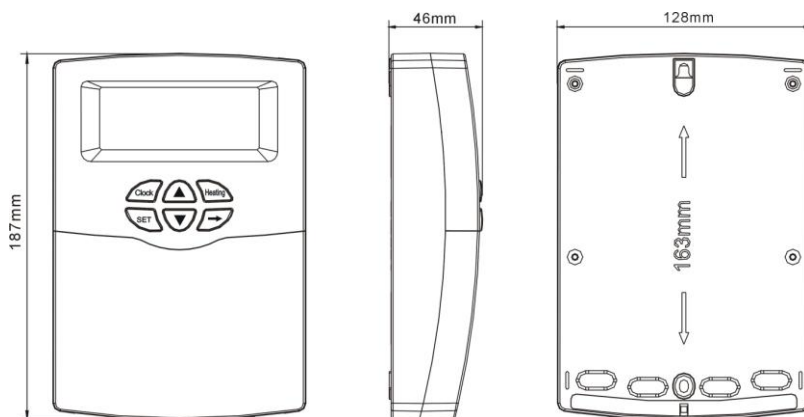

Note: the controller can only be installed in an area having an adequate level of protection.

- ▶ Choosing a suitable site
- ▶ Drilling the up fixing hole ①
- ▶ Screwing on the screw
- ▶ Taking away the cover plate
- ▶ Marking the position of fixing hole ②.
- ▶ Taking away the bottom plate.

- ▶ Drilling the hole.
- ▶ Rehanging the bottom plate on screw ①
- ▶ Fixing bottom plate with ②.

## 2.2 Power connection

Power can only be switched on only when the housing of controller is closed; an installer must make sure that the IP protection class of the controller is not damaged during installation.

Depending on the type of installation, the cables may enter the device through the rear hole of the case ③ or the lower side hole of the case ④

Cable come from the rear ③: remove the plastic flaps from the rear side of the case using an appropriate tool.

Cable come from the below ④: Cut the left and right plastic flaps using an appropriate tool (e.g. knife) and break them out of the case.

**Notes:** the flexible wire must be fastened to the case using the strain-relief clamps provided

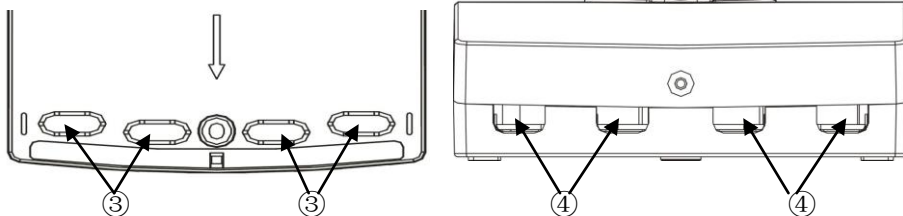

## 2.3 Terminal connection



Before to open the terminal, please be sure to switch-off the power supplier and pay attention to the local electricity supply rules.

- **Terminal layout**

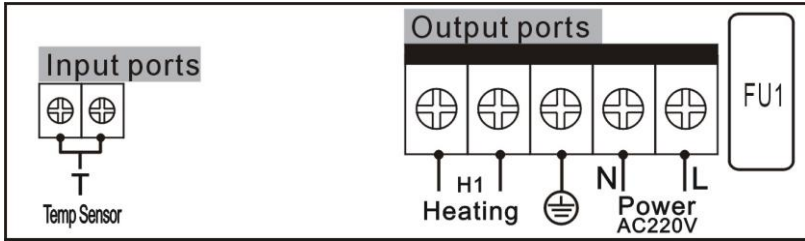

FU1 is the fuse of controller, AC250V/2A

- **Power connection**

Power input:10A,Input ports L, N is power connection terminal, please connect correctly.

 : Ground line terminal

- **Output ports**

**Electrical heater output H1:** Electromagnetic relay, max. Switching current 15A, for electrical heater

- **input ports**

**Input port T:** for NTC10K, B=3950 sensor, for measuring the temperature of tank.

- **Advice regarding the installation of temperature sensor**

Only original factory equipped NTC10K,B=3950 temperature sensor are approved for use with tank, it is equipped with 20m PVC cable, and they are temperature resistant up to 105<sup>o</sup> C, not necessary to distinguish the

positive and negative polarity of the sensor connection.

All sensor cables carry low voltage, and it is necessary to take measures to avoid inductive effects, so sensor cables should not be laid close to 230 volt or 400 volt cables (minimum separation of 100mm)

Sensor cables may be extended to a maximum length of ca. 100 meter, when cable's length is up to 50m, and then  $0.75\text{mm}^2$  cable should be used. When cable's length is up to 100m, and then  $1.5\text{mm}^2$  cables should be used.

### 3. Installation system diagram

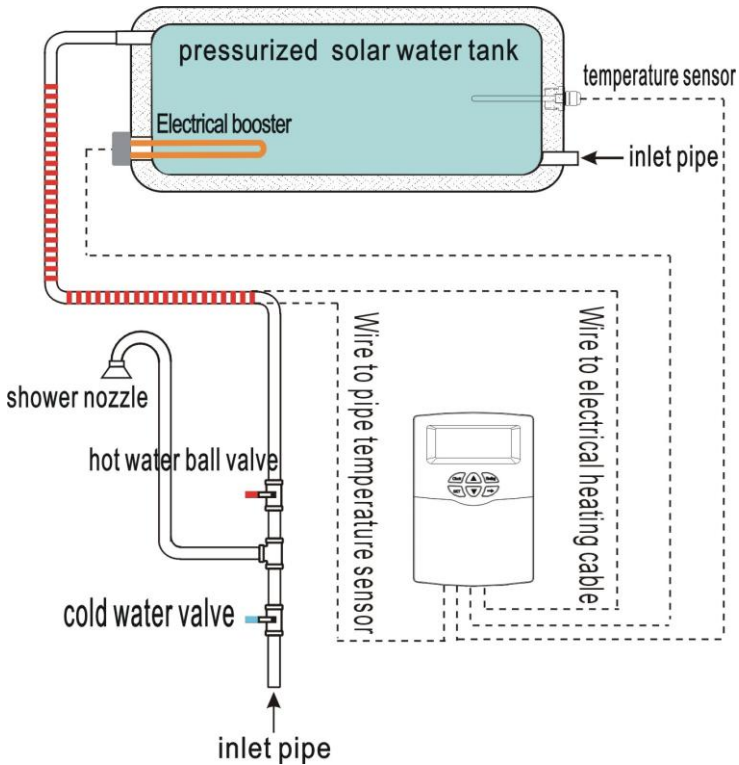



## 4. Function setting



Connect the sensor, electrical heater to the controller before you connect the power supply!

After switching on power to the controller, firstly it will ask for to set the time and set the parameter of system.

### 4.1 Display symbol and button array

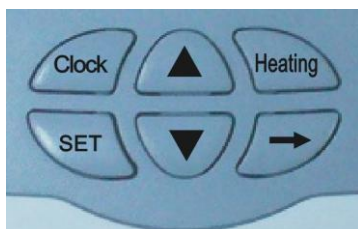
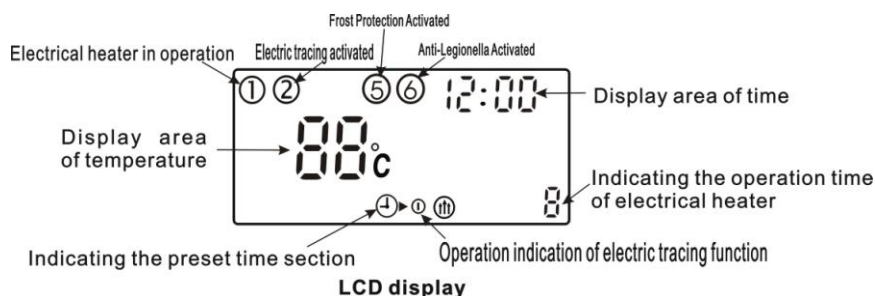

Button arrangement

### 4.2 Setting time

- ▶ Press “Clock” button, time displays on the screen, hour selection area “00” blinks on the screen.
- ▶ Press “▲▼” button to set hour of clock
- ▶ Reprress “Clock”, minute selection



area "00" blinks

- ▶ Press "▲▼" button to set minute of clock.
- ▶ After setting, press "Clock" to exit program, or waiting for 20 seconds, controller exits automatically, the setup parameters are saved automatically.

### 4.3 Manual heating

#### Description:

Electrical heater can be integrated into solar system as back-up, and it can be controlled by temperature, when controller checks the tank temperature (T) is 3°C below the preset temperature, electrical heater will be triggered. When tank temperature (T) reaches to the preset temperature, electrical heater is ceased.

**Condition for triggering heating:** preset temperature at least 3°C above tank temperature.

#### Activate/deactivate this function:

- ▶ Press "Heating" button, temperature area "60°C" blinks on the screen.
- ▶ Press "▲▼" button to adjust the switch-on temperature, adjustable range: 30°C ~ 80°C, factory default: 60°C.

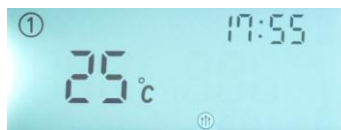

After 20 seconds, this heating function is activated, ① (H) heating signal displays on the screen.

- ▶ Press "Heating" button to switch-off manual heating function.

**Note:** manual heating can only heat tank one time, after manual heating is triggered, when temperature of tank reaches to the setting temperature, manual heating ceases, and manual heating function will be deactivated automatically, if customer wants to heat again, you need redo according to above steps.

#### 4.4 Timing heating

##### **Function description:**

Electrical heater can be integrated into solar system used as back-up of system, and they can be triggered automatically at preset time by preset temperature. Within a preset time sections, when the temperature (T) of tank drops below the preset switching-on temperature of this function, back-up heating starts to work, when T rises up to the preset turning off temperature, back-up heating is stopped. Within 24 hours, three time sections can be set with this controller.

The adjustable range of switch-on temperature of heating is 30°C ~ (OFF-3°C), the adjustable range of switch-off temperature (On+3°C) ~ 80°C.

##### **Setup steps:**

- ▶ Press “SET” button for 6 seconds, to access the setting program, set the switch-on time of the first time section and its switch-on temperature, hour area blinks on the screen.
- ▶ Press “▲▼” button, to set hour of the switch-on time of heating
- ▶ Press “→” button to transfer to minute area, minute blinks on the screen

▶ Press “▲▼” button, to set minute of the swith-on time of heating

▶ Press “→” button to transfer to temperature area, temperature blinks on the screen,



▶ Press “▲▼” button, to set the swith-on temperature of heating

▶ Repress “SET” button, to access the setting program, set the switch-off time of the first time section and its switch-off temperature, hour area blinks on the screen.



▶ Press “▲▼” button, to set hour of the swith-off time of heating

▶ Press “→” button to transfer to minute area, minute area blinks on the screen

▶ Press “▲▼” button, to set minute of the swith-off time of heating

▶ Press “→” button to transfer to temperature area, temperature blinks on the screen,

▶ Press “▲▼” button, to set the swith-off temperature of heating

▶ Press “SET” button again, to access the setting program, set the switch-on time of the second time section and its switch-on temperature. Doing like above description, to set the second / third time section and its corresponding switch-on/ switch-off temperature.

If you want to shut off one timing heating, then you can set the turning on time and turning off time same value ( for example, the second time section no this function, then you can set turning on/off time is 10:00 ~ 10:00)

① Heating signal displays on the screen, it indicates timing heating is activated.

**Note:**

When time is outside of the preset time section, back-up heating doesn't work automatically even when the tank temperature reaches the switch –on temperature of heating.

The time in this controlled is 24 hours, when you set time section, the switch-off time of heating should be later than switch-on time. For example: if you set the switch-on time of heating is at 17:00, but switch-off time of heating is 6:00, then this setting doesn't take effect, that means within this time section, heating function doesn't work. The correct set is like flowing: it should be divided into two time sections, one time section is from 17:00 to 23:59, the other time section is from 00:00 to 06:00.

When user selects electrical heater as back-up device, we recommend using SR802 unit connecting controller and electrical heater. (SR802 detailed technical data see paragraph spare parts)

## 4.5 Frost protection of collector

Description:

In Winter, the outdoor temperature is lower, in order to avoid pipe or tank damage caused by frost,when the temperature of tank is below the preset frost protection temperature(T) 2°C(factory default),electrical heater is triggered automatically.

When temperature of tank rises up to 7°C,electrical heater is ceased,exit frost protection automatically.

When electrical heating ① and frost protection ⑤ signals display on screen,it indicates "frost protection function" is activated.

**Activate /deactivate the function:**

- ▶ Press “SET” button for 6 seconds, and then continuous press “ SET” until “CF” menu appears.
- ▶ Press “ → ” button to switch on or off this function, factory default:”OFF”.
- ▶ Press “ ▲▼ ”button, to adjust the switch-on temperature of this function(adjustable range: 0 ~ 10 °C).



**4.6 Anti-Legionella function**

**Description:**

In order to avoid occurring bacteria in water tank when the temperature of tank is lower for a long time, controller will check the temperature of tank every 7 days in a period automatically, if the temperature of tank is never over 70°C(factory default) during this period, then at the factory set default time of 01:00 on the seventh day of the period auxiliary heating system is triggered automatically to heat water until it rises up to 70°C, bacteria is killed by high temperature, whereafter function is deactivated.

When electrical heating ① and anti-legionella ⑥ signals display on screen, it indicates "frost protection function" is activated.

**Activate /deactivate the function:**

- ▶ Press “SET” button for 6 seconds, and then continuous press “ SET” until “dU” menu appears.
- ▶ Press “ → ” button to switch on or off this function, factory default:”OFF”.
- ▶ Press “ ▲▼ ”button, to adjust the



switch-on temperature of this function(adjustable range: 50 ~ 90 °C).

**4.7 Pipe insulation function (optional, not available on standard functions list)**

**Note:** this function is not listed in the standard function list, if needed, please order specially.

**Function description:**

In Winter, the outdoor temperature is lower, in order to avoid pipe or tank damage caused by frost, temperature sensor ( TC) installed on the pipe will be monitored, when TC drops to the switch-on temperature ( In on) of this function, R1 output for electric tracing is triggered, and it works until the TC temperature rises up to the switch-off temperature of this function.

**Activate /deactivate the function:**

▶ Press “SET” button for 6 seconds, and then continuous press “ SET” until “InSU” menu appears.

▶ Press “ → ”button, to activate or deactivate this function.

▶ Press “SET” button, to access “ In on” menu.

▶ Press “ ▲ ▼ ”button to adjust the switch-on temperature of this function, adjustable range: 0 ~ 97 °C.

▶ Press “SET” button, to access “ In oF” menu.

▶ Press “ ▲ ▼ ”button to adjust the switch-off temperature of this function,



adjustable range: 2 ~ 99 °C.

**Note:**

When icon ② displays, it indicates the insulation function is activated.

When icon ① displays on the screen, it indicates the insulation function is in operation.

Press “▲▼” button to view the pipe temperature TC; if the sensor has fault, then when you view the temperatur TC show“---” appears on the screen, and at the same time, ① blinks on the screen.

● Connection terminal

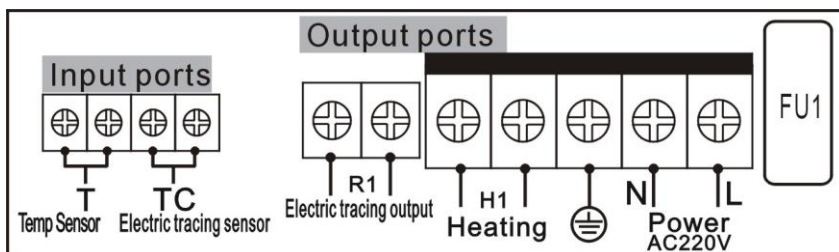

- FU1 is the fuse of controller, AC250V/6.3A
- Input of sensor TC: is the electric tracing temperature sensor, NTC10K, B=3950, ≤135°C ( PVC cable ≤ 105°C)
- Output of electric tracing R1: Electromagnetic relay, maximum switch-on currency 3.5A。

**4.8 C- F Celsius and Fahrenheit temperature transferring**

**Setup** steps:

Press “→” button and hold on for 5seconds, then select submenu C-F, “C\_F °C” displays on screen, wait for 20 seconds to exit automatically,



parameters are saved automatically.

#### **4.9 Recovery factory setting**

Under power off state, press “▼” and hold on, and power on again, buzzer makes “du-----” 3 times, then release “▼” button. Controller recovers to factory set.

### **5. Protection function**

#### **5.1. Memory protection**

In case power failure occurs, controller keeps the parameter settings unchanged.

#### **5.2 Screen protection**

When no any press on button for 3 minutes, screen protection is activated automatically, and then LCD lighting lamp is switched-off. Through press any button to light LCD lamp again.

#### **5.3 Trouble protection**

When temperature sensor's (T) wiring is interrupted, not connected or short circuit, controller switches off the corresponding signal output, and simultaneously “E1” error code displays on the screen.

### **6. Quality Guarantee**

Manufacturer provides following quality responsibilities to end users: within the period of quality responsibilities, manufacturer will exclude

the failure caused by production and material selection. A correct installation will not lead to failure. When a user takes incorrect handling way, incorrect installation, improper or crud handling, wrong connection of sensor in system and incorrect operation, the quality responsibility is invalid for them.

The warrantee expires within 12 months after the date of purchasing the controller.

## 7. Technical data

- Appearance of controller: see product itself ( dimension: 187mm x128mm x46mm).
- Power supply: 200~240V/ AC 50/60Hz.
- Power consumption: < 3W.
- Accuracy of temperature measuring:  $\pm 2^{\circ}\text{C}$ .
- Range of tank temperature measuring: 0 ~100  $^{\circ}\text{C}$ .
- Suitable power of electrical heater,  $\leq 2000\text{W}$ .
- Control-able electric tracing R1,  $\leq 600\text{W}$ (Optional)
- Input signal: T tank temperature sensor, TC, electric tracing sensor(Optional)
- Output signal: H1 for electric heater, R1 for electric tracing. (Optional)
- Ambient temperature:  $-10^{\circ}\text{C} \sim 50^{\circ}\text{C}$ .
- Water proof grade: IP40.

## 8. Delivery scope

- Controller 1 piece
- Power cable 1 piece
- Customer manual 1 piece
- Temperature sensor(T) 1 pieces
- Plastic expansion screw/ Screw/ Strain-relief clamp 1 bag

## 9. Device matchable to this controller

- Contactor unit of high power: SR802

When user selects electrical heater as back-up device, we recommend using SR802 unit connecting controller and electrical heater.

Technical data of SR802

Dimension: 100mmx100mmx65mm

Power supply:180V~264V/AC 50/60Hz

Suitable power: ≤ 4000W

Available ambient temperature: -10 ~ 50°C

Water proof grade: IP43



SR802 CONNECTION DIAGRAM:

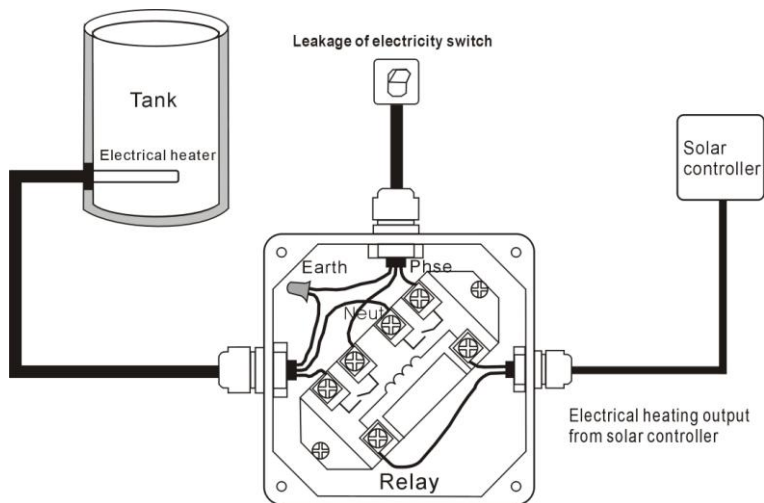

Note: Before connection, should be power off device. Only trained professional personnel may only perform installation, commissioning of the device.